

Current issues conforming to good acoustic practices	
Acoustic materials not conforming to green standards of energy efficiency, material quality etc.	Design features like natural ventilation, interior glazing for daylight, reduce sound insulation.

There is a need for holistic approach to integrate other sustainable design measures together with good acoustic design decisions while simultaneously keeping in mind the conflicts that may arise. The process should begin while conducting surveys for the existing conditions on the site.

Integrative steps for enhancing acoustic efficiency

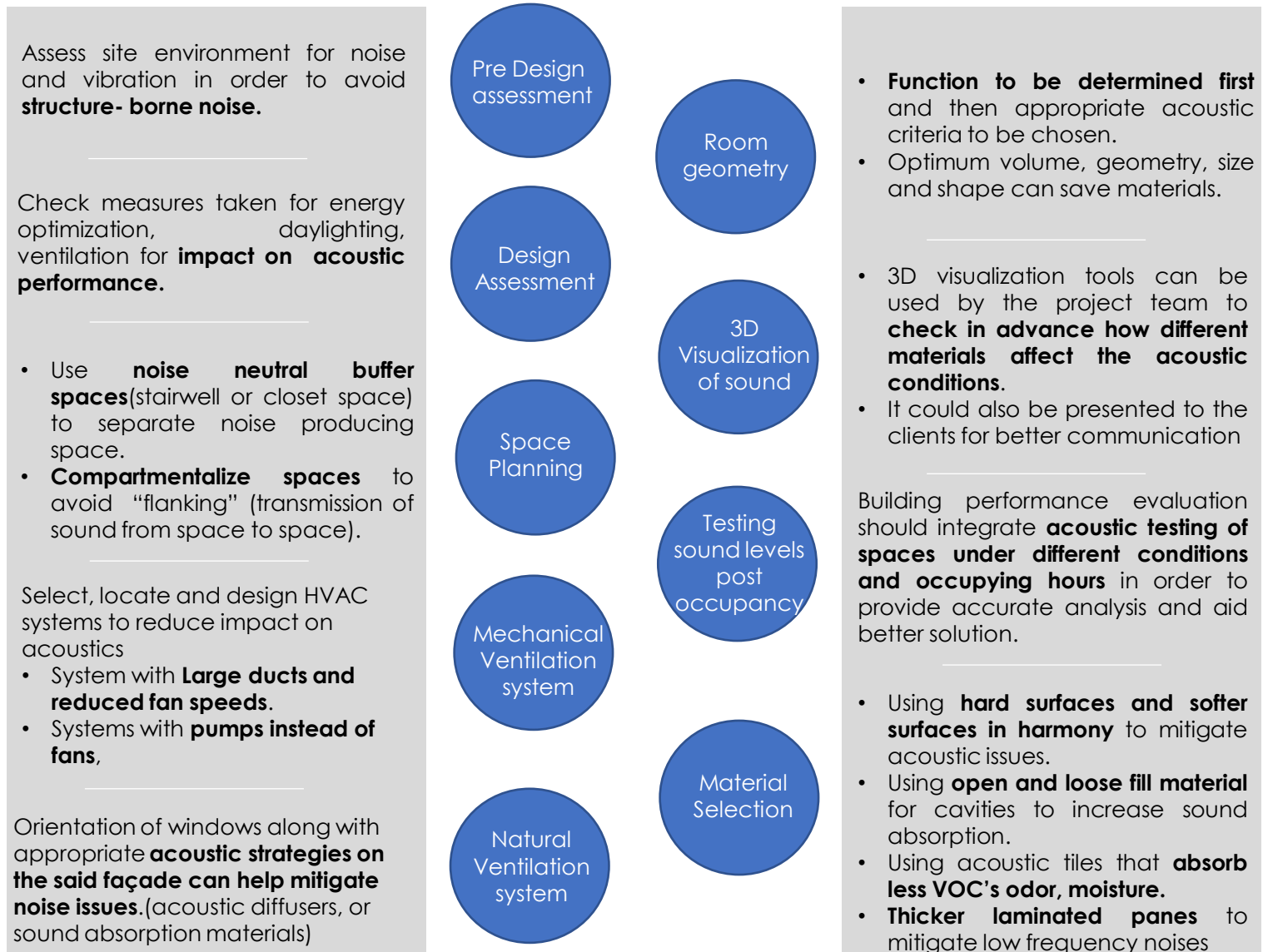

Green Rating systems with acoustic performance credit.

- WELL Building Standards: Encourages **sound mapping, efficient background sound management, sound barriers, sound absorption techniques, sound masking**, and measures taken for **impact noise management**.
- LEED v4: adaptation lies amongst **reduction of HVAC background noise, optimum sound transmission/ isolation and reverberation time** which also incorporates **enhancing envelope acoustic performance**. And is pre-requisite for buildings opting for LEED BD+C rating like schools, warehouses, new constructions etc.

Reference: <https://v2.wellcertified.com/>, <https://www.usgbc.org/>
<https://www.buildinggreen.com/>

Mechanical ventilation - Efficient duct designs

Better design

Quieter design

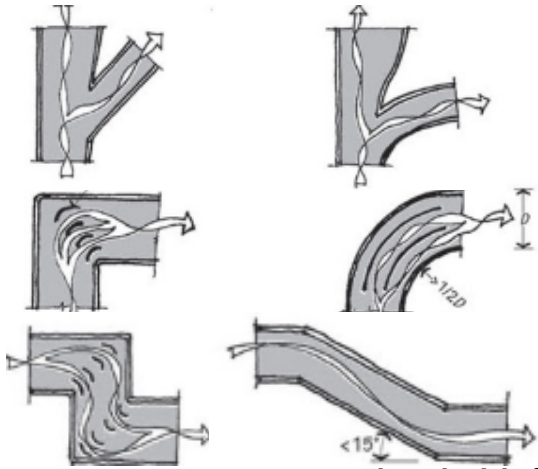

- Strategies to improve energy efficiency can make the sound emitted by system quieter.
- Using sound absorbing turning vanes within ducts can have drastic effect in the acoustic impact of system

Better design

Quieter design

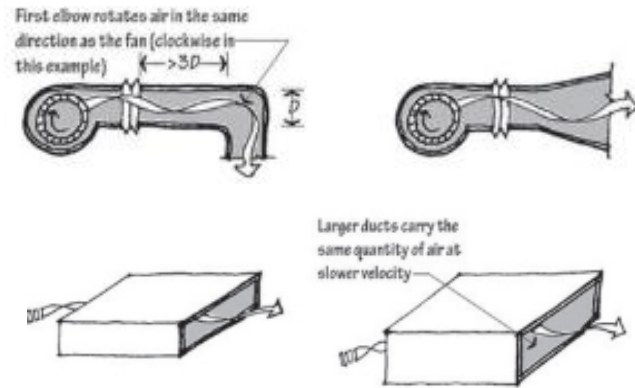

Thresholds for Background noise levels (WELL v2)

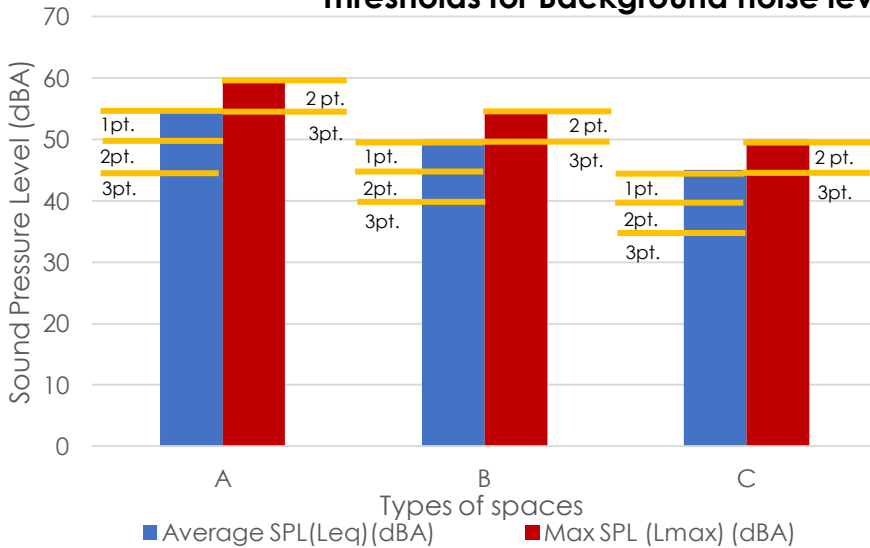

- Average SPL values can exceed upto maximum 4 dB tolerance
- Max SPL values can exceed not more than 9dB tolerance

Types Of Spaces

- A:** Open Workspaces, Dining Areas
- B:** Enclosed Offices, Residential Living and Sleeping areas (Daytime)
- C:** Conference rooms, classrooms, residential sleeping areas (Nighttime)

Minimum SPP ratings across partition For office space (WELL v2)

Receiving room	Minimum SPP	Receiving room	Minimum SPP
Enclosed Offices	75	Enclosed Offices	85
Conference Rooms	80	Conference Rooms	80
Open Offices	70	Open Offices	70

Source room : Enclosed office spaces

Source room : Conference Rooms

The sum of Background noise level and sound insulation across a partition meets minimum SPP (Speech Privacy potential ratings).

- Minimum SPP for Enclosed Quiet zones should be 75
- Walls with sliding door, SPP threshold could be 5 point less

Reference: <https://v2.wellcertified.com/>
<https://www.buildinggreen.com/>

Threshold for impact noise rating (WELL v2)

Space notation	A	B	C	D	E
Space Type	Dwelling Units	Fitness Gym, pool	Enclosed Office, Conference, Teleconference	Open Work space	Retail, Restaurant
Location Of floor-ceiling assembly	Above	Below	Above	Above	Below

Incase of pool and restaurant the space below should be with project boundary

